

Installation, Operation and Maintenance Instructions

3216CC Controller

3216CC Controller

Contents

This manual is for guidance on the use of the Carbolite Gero product specified on the front cover. This manual should be read thoroughly before unpacking and using the furnace or oven. The model details and serial number are shown on the back of this manual. Use the product for the purpose for which it is intended.

1.0	3216 Controller	4
1.1	3216CC	4
1.2	PID control	4
1.3	Operation	4
1.3.1	Controller Layout	4
1.3.2	Keys	5
1.4	Quick Start Guide	5
1.4.1	Operation as a simple controller	5
1.4.2	Changing the Setpoint	5
1.4.3	Using the Controller	6
1.4.4	Understanding User Levels	6
1.5	Setting up the Controller	7
1.5.1	Maximum Output Power	7
1.5.2	Customer ID	7
1.5.3	Units	7
1.5.4	Language	8
1.5.5	Scrolling Text	8
1.5.6	Customer Calibration	8
1.5.7	Holdback	9
1.6	Timer	9
1.6.1	Setting the Timer	9
1.6.2	Dwell Timer	10
1.6.3	Delayed Switch On Timer	10
1.6.4	Soft Start Timer	10
1.7	Running a Timer	11
1.7.1	Dwell Timer	11
1.7.2	Power Failure While Using Dwell Timer	12
1.7.3	Running Dwell Timer with Ramp Rate	12
1.7.4	Running Dwell Timer with Ramp Rate & Threshold	13
1.7.5	Delayed Switch on Timer	13
1.7.6	Running Delay Timer with Ramp Rate	13
1.7.7	Delay timer with ramp rate functions	14
1.7.8	Power Failure While Using Delay Timer	14
1.7.9	Soft start Timer	14
1.7.10	Power Failure While Using Soft Start Timer	15

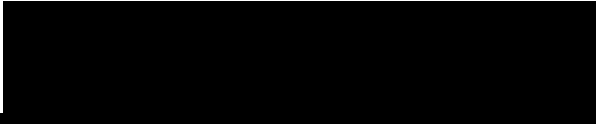

1.7.11 Ramp Rate with Soft Start Timer15
1.7.12 Time Remaining15
1.7.13 Alarms15
1.8 Controller Options16
1.8.1 Digital Communications - RS23216
1.8.2 Digital Communications - RS48516
1.8.3 Comms Address16
1.8.4 Alarm Option17
1.9 Temperature Controller Replacement17
1.10 3216CC Navigation Diagram18

1.0 3216 Controller

1.1 3216CC

This section should be disregarded unless the controller is used as an independent end zone controller.

The 3216CC Controller is a digital temperature controller which uses PID algorithms to give excellent temperature control when properly set. This controller can only be used as a simple temperature controller, it cannot be programmed.

1.2 PID control

This controller uses PID (Proportional Integral Derivative) temperature control. This type of control uses a complex mathematical control system to adjust the heating power and achieve the desired temperature.





1.3 Operation

1.3.1 Controller Layout

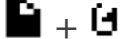

Key	
A	Power Output Indicator
B	Alarm Indicator
C	Remote Indicator (when configured)
D	Page
E	Scroll
F	Down
G	Up
H	Measurement Temperature
I	Setpoint Temperature (SP)
J	Hold Indicator
K	Run Indicator

1.3.2 Keys

Page Key		The page key is used to access level 2 when held down for 3 seconds.
Scroll Key		The scroll key is used to scroll through parameters.
Ack		When pressed simultaneously the ACK function is used to:
Page and Scroll		<ul style="list-style-type: none">• Return to the Home Menu• Acknowledge an alarm if activated.• Reset a program after the program has ended.
Arrow Keys		The arrow keys are used individually to adjust the selected parameters and in combinations to operate a program.



Note: If a parameter is selected and no further action is taken, the display will time out and revert back to the home display in its working level after approximately 1 minute.

1.4 Quick Start Guide

1.4.1 Operation as a simple controller

When switched on, the controller goes through a short test routine and then shows the measured temperature (PV = Process Value) in the upper part of the display and below it, the desired temperature (Setpoint).

1.4.2 Changing the Setpoint

Press Up  or Down  to select the required SP. If the SP is higher than the measured temperature, the OP1 indicator will illuminate in the top left corner of the display, indicating that the controller is calling for power (giving an output).

The controller will immediately attempt to reach the setpoint and then maintain it.

This will cause the product to heat as quickly as possible which may not be appropriate where the product contains sensitive ceramic components. For products with ceramic components, e.g. a tube furnaces fitted with a long ceramic work tube, use the ramp rate feature set with a low heating rate such as 5°C per minute (300°C per hour), to prevent damage.

The controller will immediately attempt to reach the set temperature and maintain it. This will cause the product to heat as quickly as possible which may not be appropriate where the product contains sensitive ceramic components. For products with ceramic components, e.g. a tube furnaces fitted with a long ceramic work tube, use the ramp rate feature set with a low heating rate such as 5°C per minute (300°C per hour), to prevent damage.

1.4.3 Using the Controller





The parameters in the controller are first shown by a short code (mnemonic). After 5 Seconds a description of the parameter will scroll once along the display and then revert back to the mnemonic. The scrolling text can be interrupted at any time by a single press of any of the buttons, but will not scroll again until the parameter is returned to. In this manual the mnemonic will be shown first, followed by the scrolling text in brackets; e.g. PROG <PROGRAM NUMBER>

1.4.4 Understanding User Levels

There are two user levels in the controller; Level 1 (Operator) and Level 2 (Supervisor). Level 1 (Operator) is for the day to day operation of the controller. These parameters are not protected by a security code.

Level 2 (Supervisor) provides access to additional parameters. Access to this level protected by a security code

To Enter Level 2



1. Press and hold the page key  for 3 seconds.
2. The display will show LEu 1 GOTO
3. Release the page Key
4. Press the up  or down  to choose LEu 2 (level 2)
5. Press the up  or down  to enter the code (Level 2 Code = 9).

If the correct code is entered, PASS should momentarily be displayed and then revert to the level 2 home display.

If an incorrect code is entered the display reverts back to Level 1 home display.

When level 2 operations have been completed, the supervisor must return to Level 1 either manually or by switching the instrument off and back on. There is no time out function.

To Return to Level 1



1. Press and hold the page Key 
2. Press down  to select LEu 1

It is not necessary to enter a code when going from a higher level to a lower level. When level 1 is selected, the display reverts to the home display (See Controller Layout)

Table showing parameters accessible in level 1 and Level 2

Operator LEVEL 1	Supervisor LEVEL 2
home display	home display
Programming	Programming
Program Status	Program Status
	Alarms (if configured)
	Current Transformer Input (if configured)



	Comms (if configured)
	Controller Setup
	Customer Calibration

TIP
 If while navigating the controller, a parameter has been passed or you need to access parameters which would be at the end of a scroll list, press and hold scroll  and use up  to return to a previous parameter.

1.5 Setting up the Controller

Before using the controller (or during its lifetime) certain parameters may have to be set, depending on specific requirements. To do this the controller must be set to supervisor level (Level 2), see section 1.4.

1.5.1 Maximum Output Power

Press scroll  until the display shows OP.HI <OUTPUT HIGH>. Use the up  and down  keys to select the output power required as a percentage. Once the setting is made, turn the instrument switch off and on to power cycle the temperature controller.



Depending on the furnace or oven model, the maximum output power setting OP.Hi may be accessible or locked.

For silicon carbide heated furnaces, the parameter is accessible to allow compensation for element ageing.

In many models the maximum output power setting depends on the supply voltage, see section 1.0.

1.5.2 Customer ID

A furnace or oven identification number can be entered if required. This maybe used to identify one of many units for production or quality control systems.

Press scroll  until the display shows ID <CUSTOMER ID>. Use the up  and down  keys to enter your own identification number. This can range from 1-9999.

1.5.3 Units

Press scroll  until the display shows UNITS <DISPLAY UNITS>. Use the up  or down  keys to select the required units.

Mnemonic	Description
NONE	No units (Default °C)
°C	Celsius
°F	Fahrenheit
°K	Kelvin
PERC	% (shows °C value)

1.5.4 Language

The scrolling text on the 3216 can be shown in different languages, this can only be set at the factory and therefore must be specified at the time of placing an order.

1.5.5 Scrolling Text

If at any time the scrolling text is not required.

Press and hold the page  for three seconds until "GOTO" is displayed.

Press scroll  until the display shows. TEXT <ENABLE/ DISABLE SCROLLING TEXT>



Use the up  and down  keys to select ON or OFF.



1.5.6 Customer Calibration



The 3216 Controller series are calibrated for life at manufacture, there may however be sensor or other system errors, which affect the accuracy of the measured temperature. Customer calibration can be used to compensate for these errors.



Dual Offset



Dual point calibration uses two offset values at two corresponding temperatures; this changes the calibration linearly as the temperature increases or decreases.

Press scroll  until the display shows CAL.P (Enter Calibration Code) Use the up  down  keys to enter the password code. (Calibration Pass Code = 95). When the correct password has been entered the display will show PNT.LO. If the wrong pass code is entered the display will revert to zero pass code, until the correct pass code is entered.

When the correct pass code is entered and PNT.LO (Adjust Low Point) is displayed. Use the up  and down  keys to enter the Low Temperature Point, which you want to apply an Offset.

Press scroll  until the display shows OFS.LO (Adjust Low OFFset). Use the up  and down  keys to enter the amount Offset you want to apply to the Low Temperature Point.

Press scroll  until the display shows PNT.HI (Adjust High Point). Use the up  and down  keys to enter the High Temperature Point, which you want to apply an Offset.

Press scroll  until the display shows OFS.HI (Adjust High OFFset). Use the up  and down  keys to enter the amount Offset you want to apply the High Temperature Point.

Once the calibration details have been entered, press scroll  until the display shows the next required parameter or return to the home list. The calibration data will now be protected by the pass code. To edit the data the above procedure must be followed.

Single Offset

If a constant offset is required across the temperature range, set the required "High Point" (PNT.HI) and "Low Point" (PNT.LO) to the required values (not the same), then set the "low Offset" (OFS.LO) and "High Offset" (OFS.HI) to the same value.





Caution! - Do not make PNT.LO and PNT.HI the same value as the controller will not work correctly and could cause the product to overheat.

1.5.7 Holdback

If the temperature ramp rate of the program is quicker than the product can achieve, the program will wait until the temperature of the product catches up.

e.g. If a holdback value of 10 is set and the program is set to ramp to a setpoint of 600 °C, the program will reach 600 °C, then go into a hold state; the hold indicator will light until the product temperature reaches 590 °C, the program will then continue to control again.

The holdback will only apply once per segment, therefore when control has been re-established, the holdback will not apply again to that segment, even if the product temperature goes outside the holdback band.

Holdback can only be accessed in supervisor level (level 2) by scrolling with the scroll  until the display shows H.BACK <PROGRAM HOLDBACK>: Use the up  and down  keys to select the required Holdback value.

If a multi programmer is used, each program can have its own holdback value assigned to it.

Note: When a holdback is set, each segment used must have a Ramp Rate assigned to it, in order for it to be recognised by the program.

1.6 Timer



1.6.1 Setting the Timer

A timer can be configured to operate in four different modes. These can be selected in level 2 (supervisor level) using the TM.CFG parameter as:-

- None
- Dwell Timer
- Delayed switch on timer
- Soft start timer

None

The timer is turned off, no timer configurations are available, the instrument works as a simple setpoint controller.



Press scroll  until the display shows TM.CFG <TIMER CONFIGURATION>. Using the up  down  select NONE.



1.6.2 Dwell Timer



A dwell timer is used to control a process at a fixed temperature for a defined period. At the end of the time period the controller will switch off the output power to the elements.

Press scroll  until the display shows TM.CFG <TIMER CONFIGURATION>. Using the up  down  select Dwell.

When Dwell parameter is selected, the Timer resolution (TM.RES), Time duration (DWELL) and Timer Threshold (THRES) functions become available.

Press scroll  until the display shows TM.RES < Time resolution >. Use the up  down  to select the timer units in Min or Hours.

Press scroll  until the display shows DWELL < SET TIME DURATION >. Use the up  down  to enter the time duration required.

Press scroll  until the display shows THres < TIMER THRESHOLD >. Use the up  down  to select the temperature threshold that you require the timer to start at. The threshold value is $\pm n$ around the setpoint (n =threshold value).

Example: If the setpoint is set to 800 °C and the timer threshold is set to 2, after the timer is activated it will not start until the process value reaches 798 °C if ramping up or 802 °C if it is cooling.

Note: If the threshold is set to OFF, the timer will either; start to count down as soon as it is activated with the mode keys or if a ramp rate has been set (see section 0.0.1), the timer will start as soon as the ramp reaches the setpoint. (see section 1.7.1)

1.6.3 Delayed Switch On Timer

The delayed switch on timer is used to switch on the output power to the elements after a set time period.

Press scroll  until the display shows TM.CFG <TIMER CONFIGURATION>. Using the up  down  select dELY.

When delay parameter is selected, the Timer Resolution (TM.RES) and Time Duration (DWELL) functions become available.

Press scroll  until the display shows TM.RES < Time Resolution >. Use the up  down  to select the timer units in Min or Hours.

Press scroll  until the display shows DWELL < SET TIME DURATION >. Use the up  down  to enter the time duration required before the output power switches on.

1.6.4 Soft Start Timer

The Soft Start Timer is used to start a process at a reduced setpoint and power. The Soft Start Setpoint is used as a threshold only and is not a control point.

Example: Main Setpoint = 800 °C



Max power limit = 75 % (This may be set at the factory)

Soft Start Setpoint = 600 °C (Threshold)



Soft Start Power Limit = 50% (Cannot be set above max power Limit)



When the timer is running, the maximum power is controlled by the Soft Start Setpoint of 600 °C and the Soft Start Power limit of 50%. This will continue until the timer ends or the current temperature exceeds the Soft Start Setpoint.



When the timer ends or the current temperature exceeds the Soft Start Setpoint, the instrument will start to control using the main setpoint of 800 °C and the Max Power Limit of 75%.



Press scroll  until the display shows TM.CFG <TIMER CONFIGURATION>. Using the up  down  select SF.st.

When Soft Start parameter is selected, the Timer Resolution (TM.RES), Time Duration (DWELL), Soft Start Setpoint (SS.SP) and Soft Start Power Limit (SS.PWR) functions become available.



Press scroll  until the display shows TM.RES < Time resolution >. Use the up  down  to select the timer units in minutes or hours.

Press scroll  until the display shows DWELL < SET TIME DURATION >. Use the up  down  to enter the time duration required, before the instrument starts to control using the main setpoint and max power.





Press scroll  until the display shows SS.SP < Soft Start Setpoint >. Use the up  down  to enter the Soft Start Setpoint.

Press scroll  until the display shows SS.PWR < Soft Start Power Limit >. Use the up  down  to enter the Soft Start Power Limit.

1.7 Running a Timer

- **Run.** This starts the timer.
- **Hold.** This stops the timer at the elapsed time. It will start again from the elapsed time when Run is selected again.
- **Reset.** This sets the timer back to zero. It can be operated again from this state.
- **End** cannot be set – it occurs automatically when the timer has counted down to zero.
- **Acknowledge** any timer after a timer has timed out using ACK function (see section 1.3.2) by pressing the  and  simultaneously.

1.7.1 Dwell Timer

Operation	Action	Indication
To RUN Timer	Press and quickly release  + 	Indicator – RUN = ON Scrolling Display – Timer Running
To HOLD timer	Press and quickly release  + 	Indicator – RUN = Flashing Scrolling Display – Timer

		Hold
To switch off Timer / Cancel	Press and hold ▲ + ▼ for more than 1 second	Indicator - RUN = OFF Scrolling Display - None Static Text - OFF
To return to home after reset	Press and hold ▲ + ▼ for more than 1 second	Indicator - RUN = OFF Display - A-M <LOOP MODE- AUTO MANUAL OFF> Use the up ▲ or down ▼ to select AUTO
	Timer Ended	Indicator - RUN = OFF Scrolling Text - Timer End Static Text - OFF
To re-RUN Timer	Press and quickly release ▲ + ▼	Indicator - RUN = ON Scrolling Display - Timer Running
To RESET timer and return to home menu after timer end	Press and quickly release Ack [Ack] + [Reset]	Indicator - RUN = OFF Scrolling Display - None
	Press and hold ▲ + ▼ for more than 1 second	Indicator - RUN = OFF Display - A-M <LOOP MODE- AUTO MANUAL OFF> Use the up ▲ down ▼ to select <i>Auto</i>

1.7.2 Power Failure While Using Dwell Timer

If there is a power failure while the timer is operating and the power is subsequently restored, the timer will reset and the static text will display "OFF" until the ▲ + ▼ keys are pressed to re-run the timer.

1.7.3 Running Dwell Timer with Ramp Rate

Set the ramp rate as outlined in section 0.0.1.

Set the dwell time as outlined in section 1.6.2.

When the timer is set to operate with a set ramp rate, the timer will not start to count down until the setpoint has been reached with the ramp, at which time the timer will begin time count down.

The scrolling display will indicate "timer running" and the run indicator will be illuminated while the ramp rate is active and during the timer count down, after which the display will indicate the instrument has switched off power to the elements (see section 1.7.7), and the run indicator will switch off.

1.7.4 Running Dwell Timer with Ramp Rate & Threshold

Set the ramp rate as outlined in section 0.0.1.

Set the dwell time as outlined in section 1.6.2.

Set the threshold as outlined in section 1.6.3.

When the timer is set to operate with a set ramp rate and threshold, the timer will not start to count down until the process temperature has reached the threshold value (see example 1.6.3).

The scrolling display will indicate "timer running" and the run indicator will be illuminated while the ramp rate is active, while the process value is reaching the threshold value and during the timer count down, after which the display will indicate the instrument has switched off power to the elements (see section 1.7.1).

1.7.5 Delayed Switch on Timer

Operation	Action	Indication
To RUN Timer	Press and quickly release ▲ + ▼	Indicator – RUN = ON Scrolling Display – Timer Running Static Text - OFF
To HOLD timer	Press and quickly release ▲ + ▼	Indicator – RUN = Flashing Scrolling Display – Timer Hold Static Text - OFF
To switch off Timer / Cancel	Press and hold ▲ + ▼ for more than 1 second	Indicator – RUN = Off Scrolling Display – None Static Text - OFF
To return to home menu. After Resetting timer	Press and hold ▲ + ▼ for more than 1 second	Indicator – RUN = Off Display – A-M <LOOP MODE-AUTO MANUAL OFF> Use the up ▲ or down ▼ to select <i>Auto</i>
	Timer Ended	Indicator – RUN = OFF Scrolling Text – Timer End
To re-RUN Timer	Press and quickly release ▲ + ▼	Indicator – RUN = ON Scrolling Display – Timer Running Static Text – OFF

1.7.6 Running Delay Timer with Ramp Rate

Set the ramp rate as outlined in section 0.0.1.

Set the delay time as outlined in section 1.6.3.

When ramp rate is active with a delay timer the run indicator serves two functions:

- Indicates timer is running
- Indicates ramp rate is active

This means that when the timer has timed out the run indicator will still be illuminated if the ramp rate is still active and will continue to be illuminated until the ramp reaches setpoint, at which time it will switch off.

A characteristic of these combinations of parameters is that the scrolling text will continue to indicate timer running when the timer has timed out. Checking whether the timer has timed out or not can be done with the 'T.REMN' function. (see section 1.7.12)

The delay timer with ramp rate will function as outlined in the table above with the addition of the functions in the following table.

1.7.7 Delay timer with ramp rate functions

	Timer Ended When ramp rate active	Indicator – RUN = ON - if ramp rate active Scrolling Text – Timer Running
To HOLD timer	Press and quickly release ▲ + ▼	Indicator – RUN = Flashing Scrolling Display – Timer Hold Static Text - OFF
To switch off Timer / Cancel	Press and hold ▲ + ▼ for more than 1 second	Indicator – RUN = ON - if ramp rate active Scrolling Display – None Static Text - OFF
To re-RUN Timer	Press and quickly release ▲ + ▼	Indicator – RUN = ON Scrolling Display – Timer Running Static Text – OFF

1.7.8 Power Failure While Using Delay Timer

If there is a power failure while the timer is operating and the power is subsequently restored, the timer will reset and will re-run from the power on time.

1.7.9 Soft start Timer

Operation	Action	Indication
To RUN Timer	Press and quickly release ▲ + ▼	Indicator – RUN = ON Scrolling Display – Timer Running Static Text - OFF
To HOLD timer	Press and quickly release ▲ + ▼	Indicator – RUN = Flashing Scrolling Display – Timer Hold

		Static Text - OFF
To switch off Timer/ Cancel	Press and hold ▲ + ▼ for more than 1 second	Indicator – RUN = OFF Scrolling Display – None Static Text - OFF
	Timer Ended	Indicator – RUN = OFF Scrolling Text – Timer End Running Soft Start Timer

When the soft start timer is set to operate, the scrolling display will indicate “timer running” and the setpoint temperature, not the soft start setpoint.

1.7.10 Power Failure While Using Soft Start Timer

If there is a power failure while the timer is operating and the power is subsequently restored, the timer will reset and will re-run from the power on time.

1.7.11 Ramp Rate with Soft Start Timer

It is not recommended that the ramp rate function be used with a soft start timer.

Note: If the temperature is already above the threshold when the timer is set to operate, the timer will time out immediately.

1.7.12 Time Remaining

The time remaining of any 'Timer' mode can be checked at any time while a timer is active.

To view the time remaining, press scroll  until the display shows T.REMN <TIME REMAINING>.

Note: The time remaining can be modified at any time while the count down timer is operating by pressing the up ▲ or down ▼ key while the time remaining function is active.

1.7.13 Alarms

Alarms are used to alert the operator when a pre-set level has been exceeded or a function error has occurred such as a sensor break. They are indicated by a scrolling message on the display and a flashing red ALM (Alarm) indicator. The alarm may also switch an output – usually a relay to allow external devices to be operated when an alarm occurs. Alarms only operate if they have been configured and are dependant on customer requirements.

How to acknowledge an alarm will depend on the type of latching which has been configured. A non-latched alarm will reset itself when the alarm condition is removed. A latched alarm requires acknowledgement with the “ACK” Function (see section 1.3.2) before it is reset.

If an alarm has been activated the red “ALM” indicator will illuminate and the scrolling text will indicate the type of alarm.

To Acknowledge an alarm and cancel the “ALM” indicator, press ACK function.

Note: The alarm indicator may seem to be permanently on when viewed from above. When an alarm is active the indicator should only be flashing, to confirm this, the controller must be viewed directly from the front.

1.8 Controller Options

As options can be ordered in a variety of combinations and for a variety of purposes, exact instructions are not given here. The full Eurotherm manual may be required to determine customer parameter settings. To reveal or hide parameters in the controllers it is necessary to go into configuration mode, a security code is needed. Please consult Carbolite Gero.

1.8.1 Digital Communications - RS232

If the RS232 option is supplied, the furnace is fitted with one sub-miniature D-socket connected to the controller comms module. RS232 is suitable for direct connection to a personal computer (PC) using a "straight through" cable as follows (the linked pins at the computer end are recommended but may not be necessary). The cable is usually 9-pin at the furnace end and 9-pin at the computer, but other alternatives are shown in parentheses.

Product end of cable female (25-pin) 9-pin			RS232 Cable: product to PC	Computer end of cable 9-pin (25-pin) male		
Rx	(2)	3	—————	3	(2)	Tx
Tx	(3)	2	—————	2	(3)	Rx
Com	(7)	5	—————	5	(7)	Com
				7,8	(4,5)	Link together
				1,4,6	(6,8,20)	Link together

1.8.2 Digital Communications - RS485

If an RS485 option is supplied, the furnace is fitted with two D-sockets. Connection between products is by "straight" cable as follows:

Product end of cable female (25-pin) 9-pin			RS485 Cable: product to PC	Computer end of cable 9-pin (25-pin) female		
-	(2)	3	=====	3	(2)	Tx
+	(3)	2	=====	2	(3)	Rx
Com	(7)	5	—————	5	(7)	Com

1.8.3 Comms Address

Typically the comms address is set to 1, but this can be changed. In the case of RS485 and multiple instruments it is necessary to set different addresses. To change the

address value, access the level 2 list. In level 2 press the page key until the COMMS parameter is displayed. Press up ▲ down ▼ to select the address value.

1.8.4 Alarm Option

When an alarm board is fitted, which consists of a relay with voltage free contacts, for operator use, the contacts are taken to a panel plug on the control panel, wired as indicated:

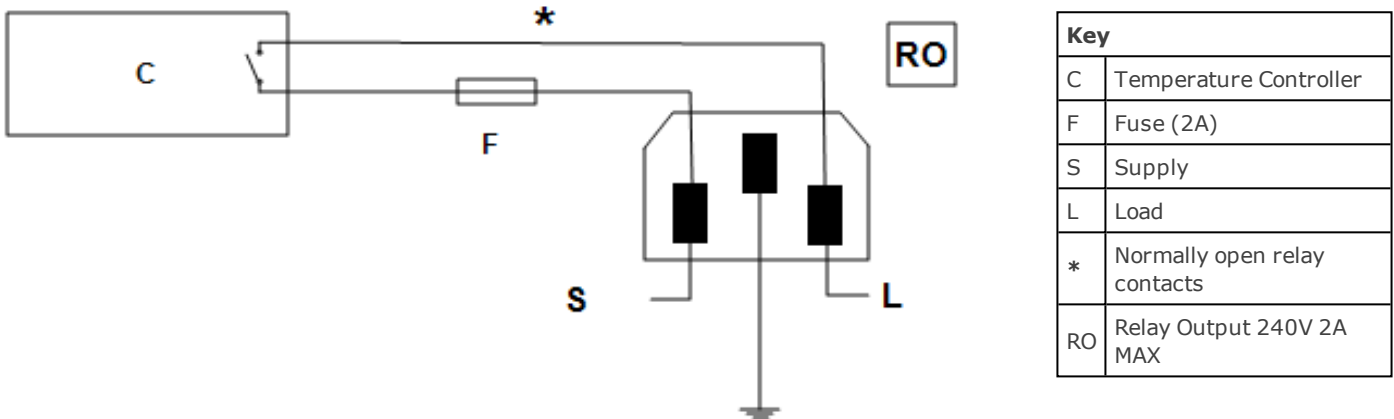

The purpose of the 2 amp fuse is to break the circuit to prevent overloading on the circuit due to high voltage.

The instrument configuration and parameters available to the operator depend on the customer requirements.

1.9 Temperature Controller Replacement



Before handling the controller: wear an anti-static wrist strap or otherwise avoid any possibility of damage to the unit by static electricity. Refer to the detailed instructions supplied with the replacement controller.

Ease apart the two lugs at the side; grip the instrument and withdraw it from its sleeve; push in the replacement.

1.10 3216CC Navigation Diagram

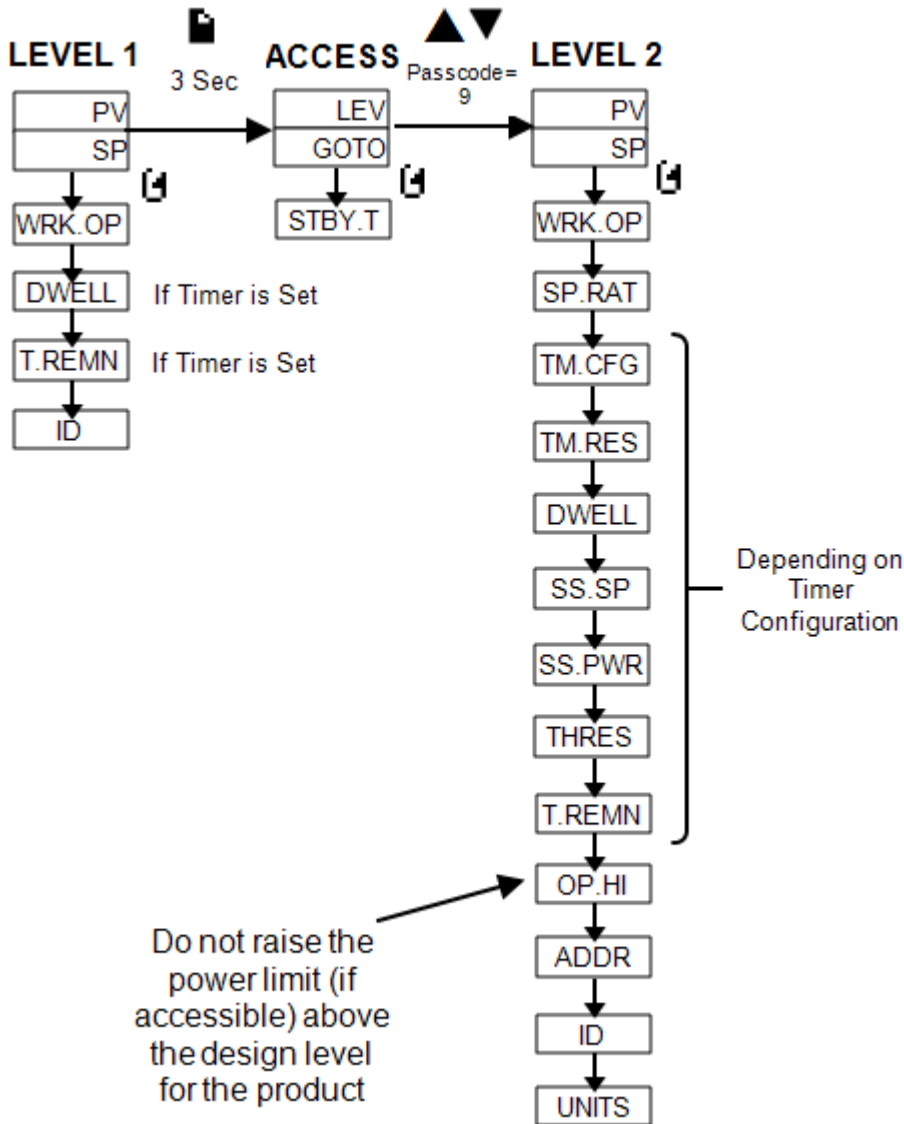

ProductLabel

The products covered in this manual are only a small part of the wide range of ovens, chamber furnaces and tube furnaces manufactured by Carbolite Gero for laboratory and industrial use. For further details of our standard or custom built products please contact us at the address below, or ask your nearest stockist.

For preventive maintenance, repair and calibration of all furnace and oven products, please contact:

Carbolite Gero Service

Telephone: + 44 (0) 1433 624242

Fax: +44 (0) 1433 624243

Email: ServiceUK@carbolite-gero.com

Carbolite Gero Ltd,

Parsons Lane, Hope, Hope Valley,
S33 6RB, England.

Telephone: + 44 (0) 1433 620011

Fax: + 44 (0) 1433 621198

Email: Info@carbolite-gero.com

www.carbolite-gero.com

CARBOLITE
GERO 30-3000°C

Copyright © 2018 Carbolite Gero Limited